

# Hi-TECH 550

15"-18" Chucker Horizontal Turning Center





# 15"-18" CHUCKER HORIZONTAL TURNING CENTER

## High Performance Mid-size 15"-18" Horizontal Turning Center

Hi-TECH 550 is equipped with the extra rigid tool post of highest durability to deliver the most stable, precision machining performance even at hard turning.

1 Spindle Housing/Machine Tool Industry/SM45C    2 Motor Housing/Machine Tool Industry/SM45C

3 Valve Body/Industrial Material/CF8M    4 Spindle Shaft/Machine Tool Industry/SNCM420



# HEAVY DUTY CUTTING WITH BOX WAY & GEAR BOX TYPE

Hwacheon's Hi-TECH 550 incorporates tough box way design which makes it an ideal turning center for heavy duty hard turning. It's equipped with a long bed for extra-length workpieces, and with the programmable tailstock and steady rest for stability and precision. Machining precision is enhanced even further because all of the Hi-TECH 550's axes can be installed with highly accurate linear scales; and the fast turret indexing time of 0.2 seconds per step will increase your productivity.





**Hand-Scraped to Perfection**

The guide-ways are hand-scraped and polished to the highest precision based on Hwacheon's 60 years craftsmanship experience, this to reduce vibration and allows precision feed during heavy operations.



**Box Way Design**

Hi-TECH 550's box way guide design improves rigidity and precision after many hours of continued operation.

**High Performance Spindle**

Hwacheon's unique spindle technology delivers quality and precision at high speed cutting.

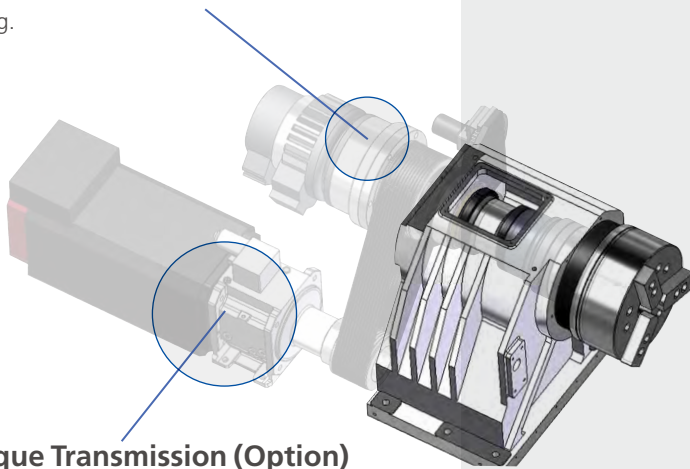

**High Torque Transmission (Option)**

The gear-driven transmission provides power and versatility. It provides high torque at low speeds without compromising high-speed operation and performance. The transmission assembly and the spindle motor have been designed away from the spindle to limit heat and vibration transfer.

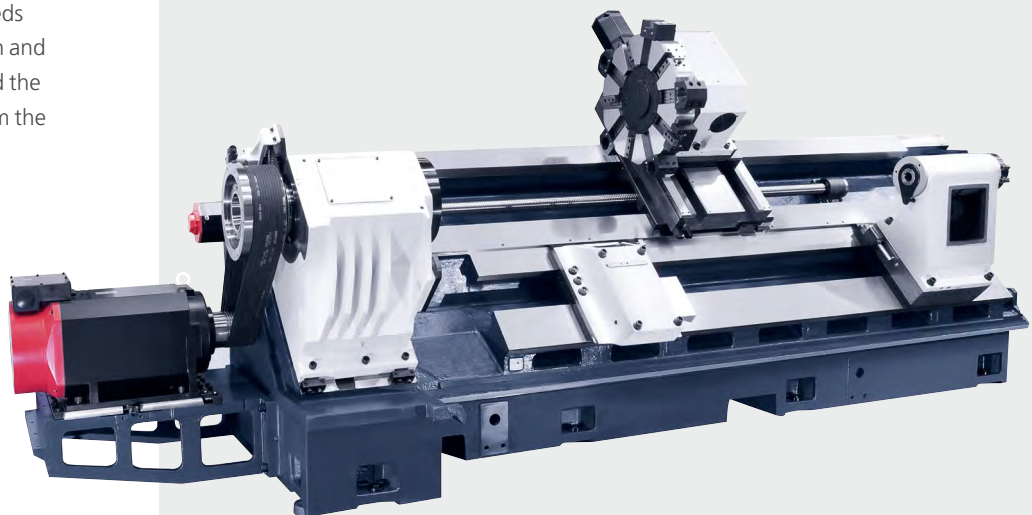

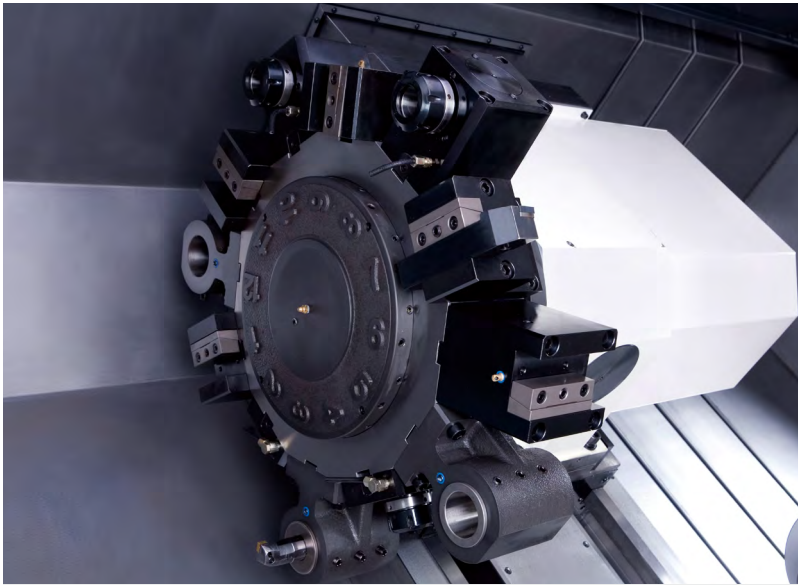

### **Tough, Rapid Indexing Turret**

The turret in Hi-TECH 550 with a powerful clamping force offers an index time of 0.2sec/step for faster, more stable machining.

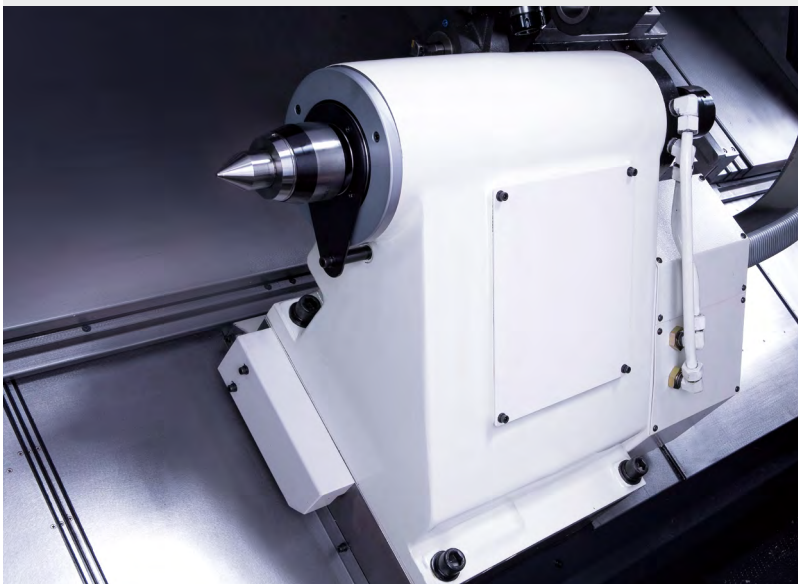

### **Programmable Tailstock (Standard)**

The tailstock can be programmed to position itself in semi-auto, and it provides firm support for extra-long workpieces to guarantee machining precision. The tail spindle can be operated either by the foot switch or by programming, while providing firm, stable oil-pressure chucking.



### **Steady Rest (Option)**

Add the Steady rest when working with extra-long workpieces to raise machining precision.

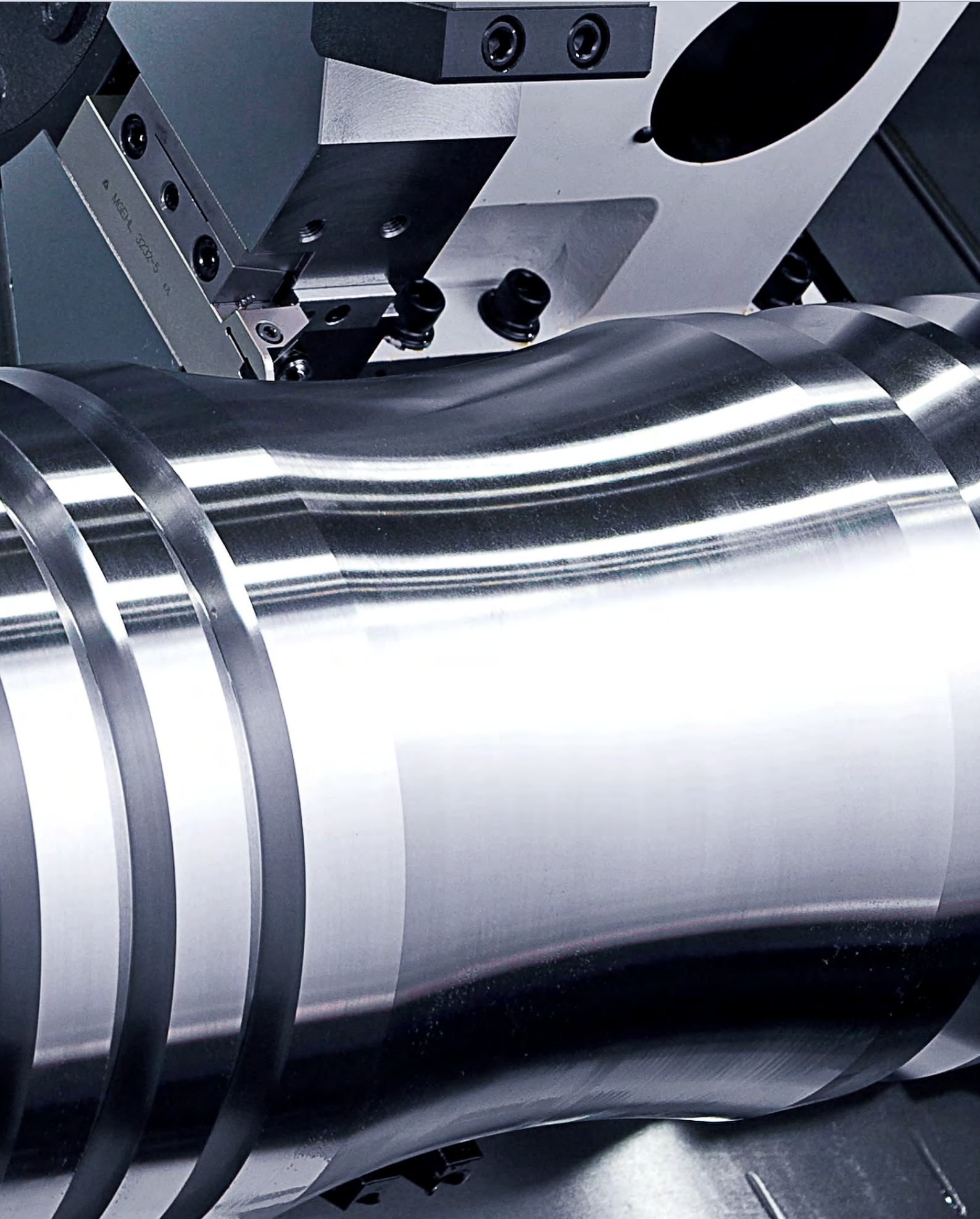

# USER FRIENDLY DESIGN, A WIDE RANGE OF OPTIONAL FEATURES

Hi-TECH 550 is designed to be user friendly, so you can concentrate on what you do best: creating quality products—without losing your valuable time to the worries of machine failure and safety. A wide variety of performance upgrade options are available for faster, more precise machining.

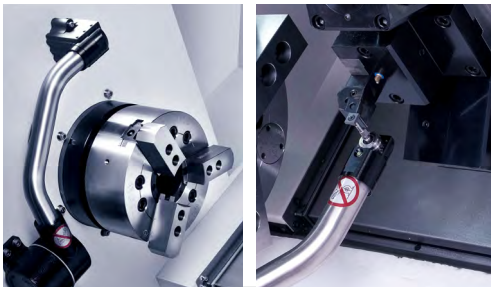

### Tool Presetter (Option)

The tool presetter employs a highly accurate sensor to precisely compute for the coordinate settings in less than 15 seconds per tool. Different tool shapes and their tolerance values are entered automatically for the coordinate calculations.



### Linear Scale (Option)

To determine the coordinates with the highest of accuracy, and to correct the axis coordinate error caused by thermal displacement, the magnetic absolute output linear scales can be installed on all axes.

## L-HTLD: Hwacheon Lathe Tool Load Detect System (Standard)



The Hwacheon Lathe Tool Load Detect System constantly detects and diagnoses the tool load under a process to prevent tool wear and damage, and to keep your machine and tools in optimal shape.

### Load Detection Limit 1

#### Alarm + Feed Hold

> When the LIMIT 1 Alarm sounds, the system holds the feed and the machine goes into standby.

### Load Detection Limit 2

#### Alarm + Machine Stop

> When the LIMIT 2 Alarm sounds, the system stops the machine, and must be reset to operate it.

Product Data

\* Unit: mm(inch)

L : Long Bed  
XL : Extra Long Bed

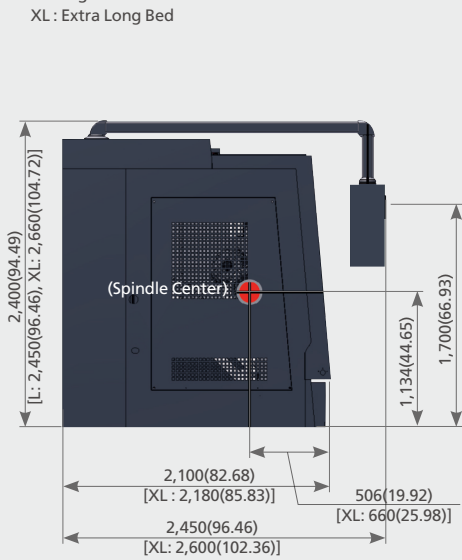

Left Side

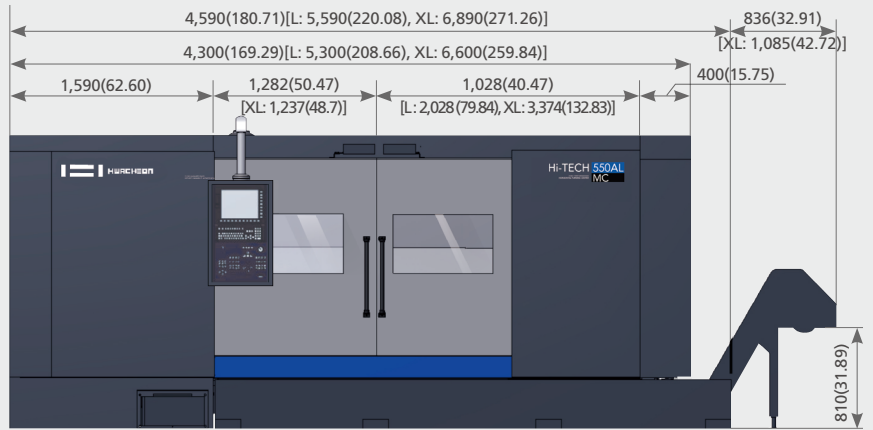

Front

Spindle Power-Torque Diagram

Standard

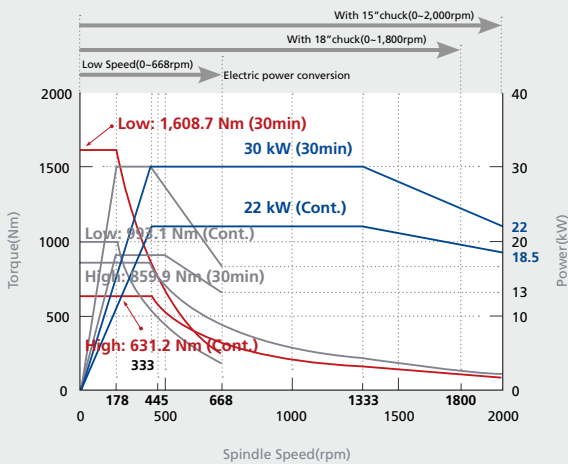

Option(with Gear Box)

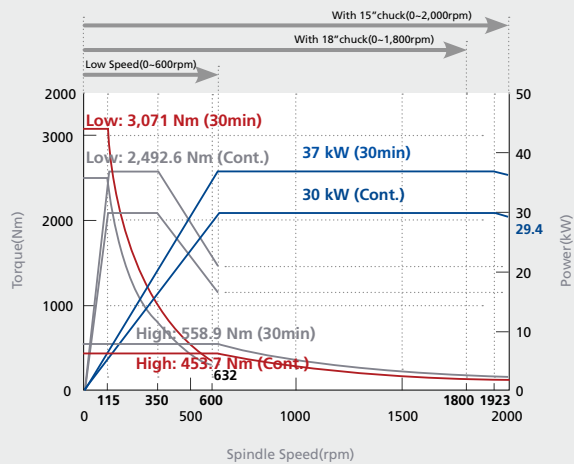

Tool Interference Diagram

※Unit : mm(inch)

STD 10 Station

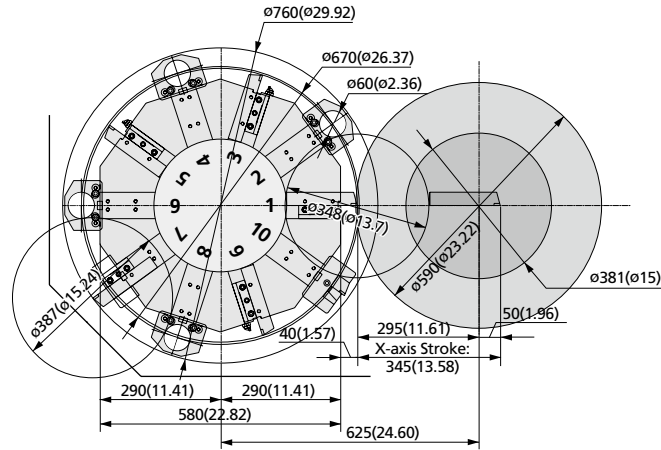

12 Station

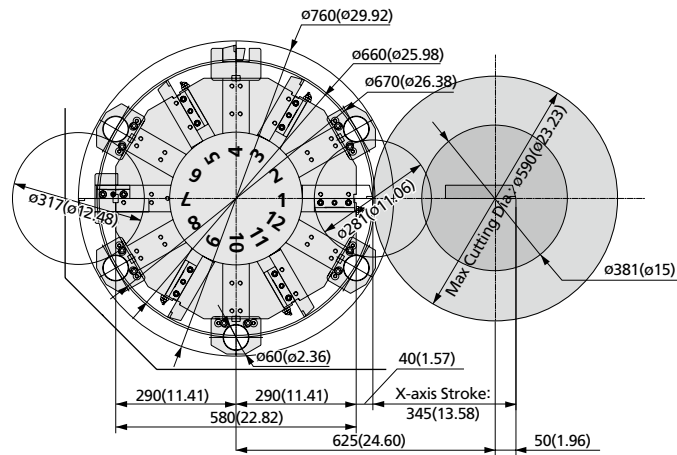

MC

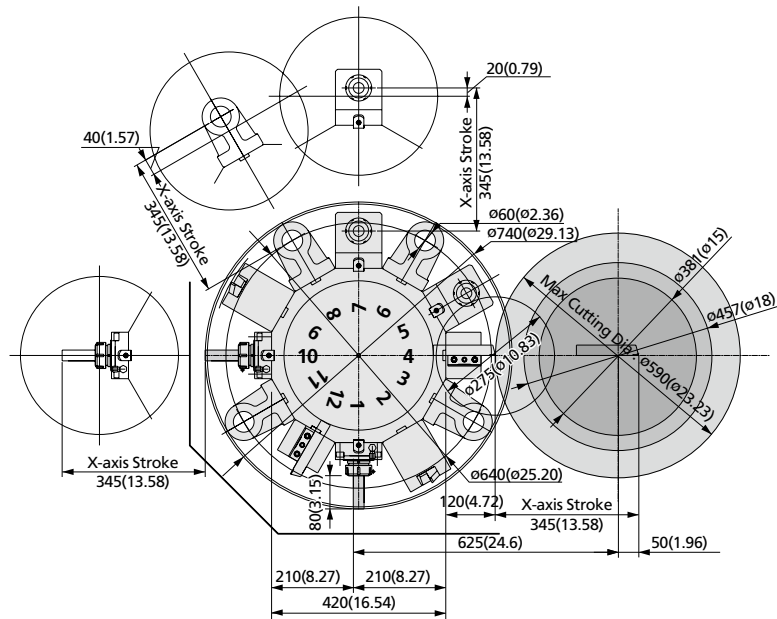

Moving Range

※Unit : mm(inch)

O.D Holder

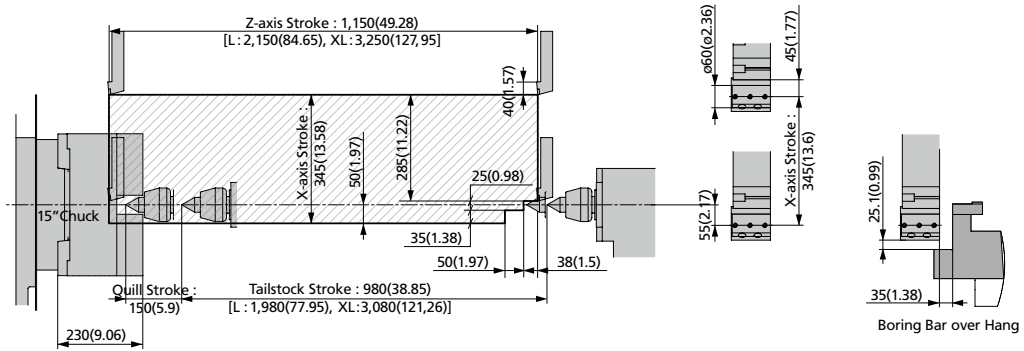

MC

O.D Holder

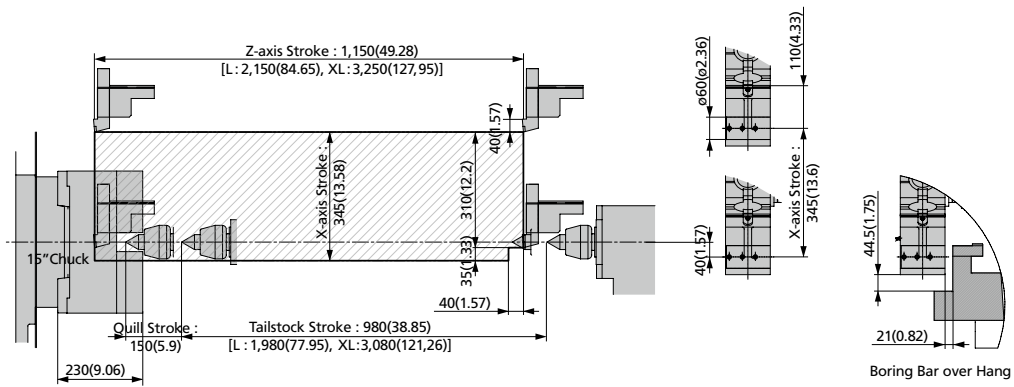

Radial Turnmill Holder

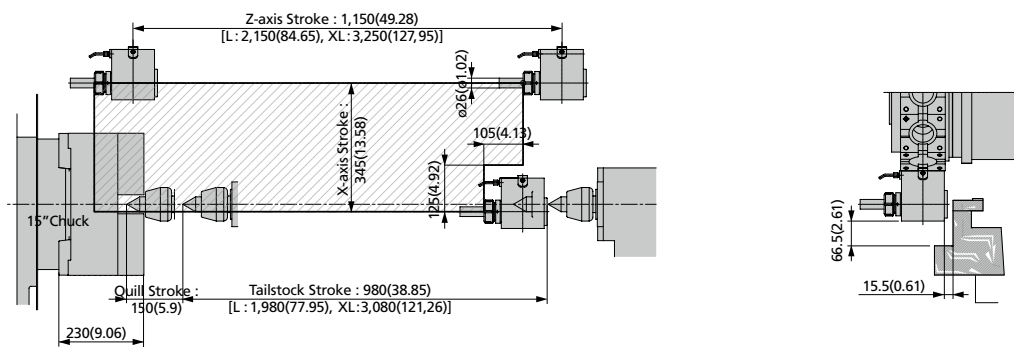

Axial Turnmill Holder

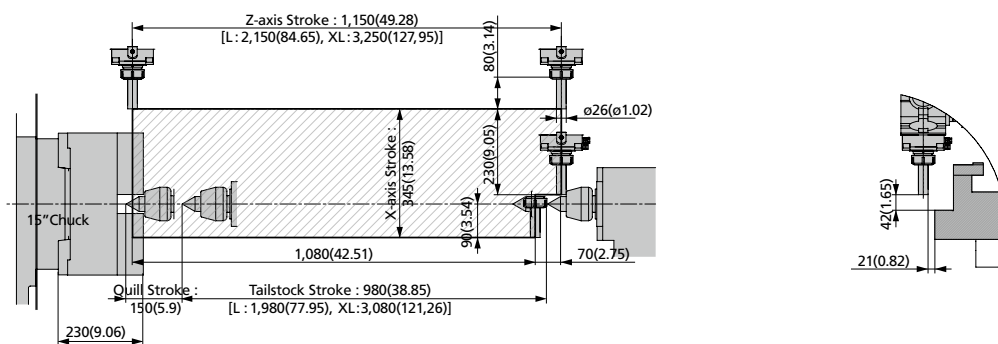

## Product Configuration

Each product can be configured to fit your application.

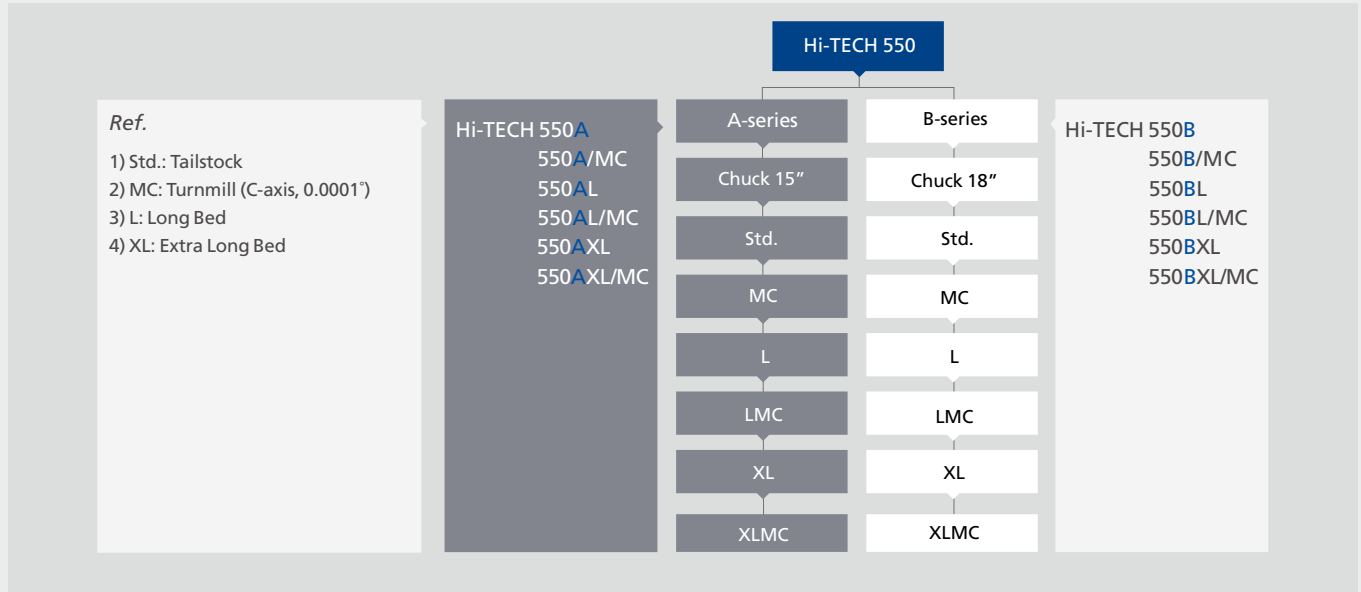

## Machine Specifications

ITEM	HI-TECH 550 SERIES						
	550A / AMC	550AL / ALMC	550AXL / AXLMC	550B / BMC	550BL / BLMC	550BXL / BXLMC	
<b>Capacity</b>							
Swing over Bed	mm (inch)	Ø800 (Ø31.50)					
Max Cutting Diameter	mm (inch)	Ø590 (Ø23.23)					
Standard Cutting Diameter	mm (inch)	Std.: Ø387 (Ø15.23), MC: Ø275 (Ø10.83)					
Max Cutting Length	mm (inch)	1,100 (43.31)	2,100 (82.68)	3,200 (125.98)	1,100 (43.31)	2,100 (82.68)	3,200 (125.98)
Chuck Size	inch	15			18		
<b>Spindle</b>							
Type of Spindle Nose	ASA	A2-11					
Max Spindle Speed	rpm	2,000			1,800		
Through Spindle Hole Diameter	mm (inch)	Ø132 (Ø5.20)					
Max Bar Size	mm (inch)	Ø116 (Ø4.57)					
Spindle Bearing Inner Diameter	mm (inch)	Ø180 (Ø7.09)					
Spindle Motor	kW (HP)	30 / 22 (40 / 30)					
<b>Turret</b>							
Number of Tool Station	ea	Std.:10 (Opt.: 12), MC:12					
Tool Size	mm (inch)	□32 x Ø60 (□1.25 x Ø2.5)					
Turret Indexing Time	sec / step	0.2					
<b>Feed rates</b>							
Rapid Traverse (X/Z)	m/min (ipm)	20 / 24 (787 / 945)	20 / 20 (787 / 787)	20 / 10 (787 / 394)	20 / 24 (787 / 945)	20 / 20 (787 / 787)	20 / 10 (787 / 394)
Max Stroke (X/Z)	mm (inch)	345 / 1,150 (13.58 / 45.28)	345 / 2,150 (13.58 / 84.65)	345 / 3,250 (13.58 / 127.95)	345 / 1,150 (13.58 / 45.28)	345 / 2,150 (13.58 / 84.65)	345 / 3,250 (13.58 / 127.9)
Feed Motor (X/Z)	kW (HP)	4 / 4 (5.4 / 5.4)	4 / 7 (5.4 / 9.5)		4 / 4 (5.4 / 5.4)	4 / 7 (5.4 / 9.5)	
<b>Tailstock</b>							
Quill Dia	mm (inch)	Ø120 (Ø4.72)					
Quill Stroke	mm (inch)	150 (5.91)					
Quill Taper	MT	# 5					
<b>Turnmill</b>							
Spindle Motor	kW (HP)	7.5 / 5.5 (10 / 7.5)					
Max Spindle Speed	rpm	4,000					
Max Drill/Tap Size	mm (inch)	Ø32 (Ø1.26) / M20					
Min Index Angle	deg	0.0001					
<b>Tank</b>							
Lubrication	ℓ(gal)	12 (3.17)					
Hydraulic	ℓ(gal)	50 (13.21)					
Coolant	ℓ(gal)	250 (66)	380 (100)	580 (153)	250 (66)	380 (100)	580 (153)
<b>Power Sources</b>							
Electrical Power Supply	kVA	65					
<b>Dimension</b>							
Height	mm (inch)	2,400 (94.49)	2,450 (96.46)	2,660 (104.72)	2,400 (94.49)	2,450 (96.46)	2,660 (104.72)
Floor Space (LxW)	mm (inch)	4,590 x 2,450 (180.71 x 96.46)	5,590 x 2,450 (220.08 x 96.46)	6,890 x 2,600 (271.26 x 102.36)	4,590 x 2,450 (180.71 x 96.46)	5,590 x 2,450 (220.08 x 96.46)	6,890 x 2,600 (271.26 x 102.36)
Weight	kgf (lb <sub>f</sub> )	Std.: 10,700(23,589) MC: 11,200(24,692)	Std.: 13,000(28,660) MC: 13,500(29,762)	Std.: 16,300(35,935) MC: 16,800(37,038)	Std.: 10,900 (24,030) MC: 11,400 (25,133)	Std.: 13,200(29,101) MC: 13,700(30,203)	Std.: 16,500(36,376) MC: 17,000(37,479)
<b>NC Controller</b>							
Fanuc 0i-TF Plus							

## Standard and Optional Product Components

Standard Accessories		Optional Accessories	
• Built in tailstock (only XL Type)	• Leveling Bolt & Plate	• Air Blower	• Part Catcher
• Coolant System	• Manual Guide i	• Air Gun	• Set of Hard Jaw
• Door Interlock	• Multiple Repetitive Cycle 2	• Bar Feeder Interface	• Spindle Motor Upgrade
• Dual Pressure (C-axis brake)	• Operation Manual & Part List	• Chip Conveyor & Box (Side Type)	37/30 kW with gear box
• Foot Switch	• Set of Soft Jaws	• Chuck Clamp/Unclamp Confirm Switch	• Steady Rest
• Hydraulic Chuck - Hollow	• Signal Lamp with 3 Colors (R, G, Y)	• Chuck Pressure Check Switch	• Steady Rest Base
- Hi-TECH 550A: 15"	• Tailstock (MT#5)	• Chuck Pressure Compensation	• Tool Presetter (Automatic type)
- Hi-TECH 550B: 18"	- Tailstock Body Program	• Coolant Gun	• Tool & Work Counter, External / Internal
• Hydraulic Unit (40kg/cm <sup>2</sup> )	- Tailstock Quill Program	• Dual Pressure (Chuck)	• Transformer
•HLVC	• Tooling System	• High Pressure Coolant System,	• Turnmill Function Including C-Axis (0.0001")
(Hwacheon Lathe Vibration Control)	• Tool Kit & Box	0.6 / 1.5 MPa	• Turnmill Spindle Motor Upgrade, 11/7.5kW
•L-HTLD	• Tool Life Management	• Linear Scale (X / Z)	• Turnmill Holder (Axial / Radial)
(Lathe-Hwacheon Tool Load Detect)	• Work Light	• NC Cooler	• U-Drill Holder
•L-CAL	•15" Non touch display (only FANUC)		•15" Touch type display (only FANUC)
(Lathe Calculator Function)			
•L-COUNT			
(Work / Tool Counter Management)			

## NC Specifications [Fanuc Oi-TF Plus]

※ : Not available S : Standard O : Option

ITEM	SPECIFICATION	STD	MC	ITEM	SPECIFICATION	STD	MC
Controlled axis				Program input			
Controlled axis (Cs axis)	2-Axes	2-Axes	3-Axes	Decimal point programming		S	S
Simultaneously controlled axes	2-Axes	2-Axes	3-Axes	Coordinate system setting	G50	S	S
Least input increment	0.001mm, 0.0001deg, 0.0001inch	S	S	Coordinate system shift		S	S
Least input increment 1/10	0.0001mm, 0.00001inch	O	O	Workpiece coordinate system	G52-G59	S	S
inch/metric conversion	G20, G21	S	S	Workpiece coordinate system preset	G92.1	S	S
Stored stroke check 1,2,3		S	S	Direct drawing dimension programming		S	S
Chamfering on/off		S	S	G code system	A	S	S
Backlash compensation		S	S	Programmable data input	G10	S	S
Operation				Sub program call	10Folds Nested	S	S
Automatic & MDI operation		S	S	Custom macro B		S	S
Program number search		S	S	Addition of custom macro -common variables	#100-#199, #500-#999	S	S
Sequence number search		S	S	Canned cycles		S	S
Dry run, single block		S	S	Multiple repetitive cycle		S	S
Manual handle feed	1Unit	S	S	Multiple repetitive cycle II		S	S
Manual handle feed rate	x1, x10, x100	S	S	Canned cycles for drilling		S	S
Interpolation function				Manual Guide i		S	S
Positioning	G00	S	S	Spindle speed function			
Linear interpolation	G01	S	S	Constant surface speed control	G96 / G97	S	S
Circular interpolation	G02, G03	S	S	Spindle override	0-150%	S	S
Dwell (Per seconds)	G04	S	S	Spindle orientation		S	S
Polar coordinate interpolation	G12.1/G13.1	-	S	Rigid tapping		S	S
Cylindrical interpolation	G7.1	-	S	Spindle synchronous control		-	-
Threading	G32	S	S	Editing operation			
Multiple threading		S	S	Part program storage length	5,120 m (2MB)	S	S
Threading retract		S	S	Number of register able programs	Max.1000 ea	S	S
Continuous threading		S	S	Background editing		S	S
Variable lead threading	G34	S	S	Extended part program editing		S	S
Reference position return 1st	G28	S	S	Play back		S	S
Reference position return check	G27	S	S	Operation/Display			
2,3,4th reference position return	G30	S	S	Clock function		S	S
Arbitrary speed threading		O	O	Self-diagnosis function		S	S
Feed function				Alarm history display		S	S
Rapid traverse override	F0, F25, F50, F100	S	S	Help function		S	S
Feed per minute (mm/min)	G98	S	S	Run hour and parts count display		S	S
Feed per revolution (mm/rev)	G99	S	S	Graphic function		S	S
Rapid traverse bell-shaped acceleration/deceleration		S	S	Multi-language display	English, German, French, Italian, Chinese, Spanish, Korean, Portuguese, Polish, Hungarian, Swedish, Russian	S	S
Feedrate override	0-150 %	S	S				
Jog feed override	0-1,260 mm/min	S	S	Data input/output			
Tool function / compensation				Ethernet interface		S	S
Tool function	T4-digits	S	S	Memory card interface		S	S
Tool offset pairs	128pairs	S	S	USB card interface		S	S
Tool nose radius compensation		S	S	Others			
Tool geometry/wear compensation		S	S	Display Unit	15" Non touch display	S	S
Tool life management		S	S	Fanuc i-HMI	15" Touch type display	O	O
Automatic tool offset	Tool presetter option is required	S	S	HWACHEON Machining Software			
Direct input tool offset value measured B	Tool presetter option is required	S	S	L-HTLD (Hwacheon Tool Load Detect System)		S	S
Program input				L-CAL (Lathe Calculator Function)		S	S
Tape code	EIA / ISO	S	S	L-COUNT (Work / Tool Counter Management)		S	S
Optional block skip	9ea	S	S	HLVC (Hwacheon Lathe Vibration Control)		S	S
Program number	O4-digits(1-9999)	S	S	M-VISION Pro		O	O
Sequence number	N8-Digits	S	S				

## Hwacheon Global Network

 Hwacheon Headquarter  Hwacheon America  Hwacheon Europe  Hwacheon Asia



**HWACHEON**

Please contact us for product inquiries.

[www.hwacheon.com](http://www.hwacheon.com)

The product design and specifications may change without prior notice.  
Read the operation manual carefully and thoroughly before operating the product,  
and always follow the safety instructions and warnings labels attached on the surfaces of the machines.

### HEAD OFFICE

#### HWACHEON MACHINE TOOL CO., LTD.

123-17, HANAMSANDAN 4BEON-RO, GWANGSAN-GU, GWANGJU, KOREA  
TEL: +82-62-951-5111 FAX: +82-62-951-0086

### SEOUL OFFICE

46, BANGBAE-RO, SEOCHO-GU, SEOUL, KOREA  
TEL: +82-2-523-7766 FAX: +82-2-523-2867

### USA

#### HWACHEON MACHINERY AMERICA, INC.

555 BOND STREET, LINCOLNSHIRE, ILLINOIS, 60069, USA  
TEL: +1-847-573-0100 FAX: +1-847-573-9900

### SINGAPORE

#### HWACHEON ASIA PACIFIC PTE. LTD.

21 BUKIT BATOK CRESCENT, #08-79 WCEGA TOWER,  
658065, SINGAPORE  
TEL: +65-6515-4357 FAX: +65-6515-4358

### VIETNAM

#### HWACHEON MACHINE TOOL VIETNAM CO., LTD.

HCM: TRANING CENTER, KCM CAO, Q.9, HCMC, VIET NAM  
TEL: +84-28-6275-7011  
HN: SO 11, D. HUU NGHI, VSIP BAC NINH, VIET NAM  
TEL: +84-22-2390-8981

### GERMANY

#### HWACHEON MACHINERY EUROPE GMBH

JOSEF-BAUMANN STR. 25, 44805, BOCHUM, GERMANY  
TEL: +49-234-912-816-0 FAX: +49-234-912-816-60

### INDIA

#### HWACHEON MACHINE TOOL INDIA PVT. LTD.

LUNKAD SKY VISTA, UNIT NO.202, 2ND FLOOR PLOT NO.84,  
LOHEGAON, VIMAN NAGAR, PUNE 411014, INDIA  
TEL: +91-96-73-986633

### CHINA

#### HWACHEON MACHINE TOOL CHINA CO., LTD.

B03A LIANGUAN JUHE INTERNATIONAL HARDWARE CITY, NO.  
143 ZHENANZHONG ROAD, JINXIA, CHANGAN TOWN,  
DONGGUAN CITY, GUANDONG PROVINCE, CHINA #523852  
TEL: +86-769-8932-0601 FAX: +86-769-8932-0602